



Standard Three-Axis Servo Driven Robot

ST3-900-1600T-S2



Refer carefully to this manual before operation.

■ Coding Principle

S T 3 - xxx - xxx L H T - S - I

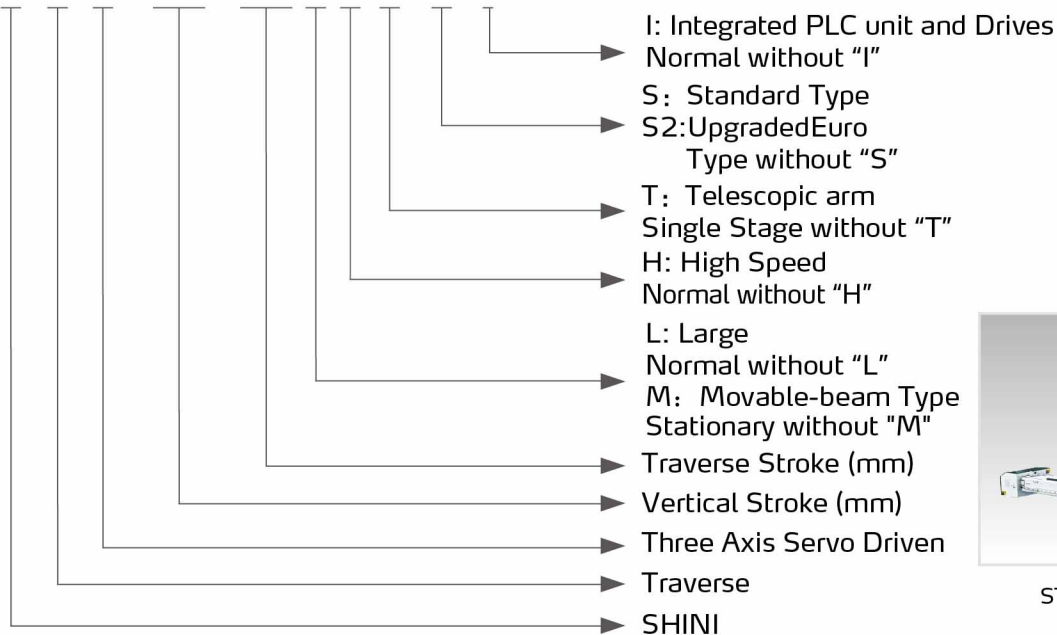

Home Page



ST3-2200-3000LT-S

■ Features

- Precision
All linear movements are driven by heavy duty servo motors with cooperation of precise linear guide rails and high power V belts; fast, silent, and precise. Wrist mechanism employs pneumatic driven rack and pinion system, which accomplishes smooth, stable and precise flipping motion. Vertical arm with telescopic design efficiently minimizes the cycle time and height of the robot.
- Safety
The travel limit of the X, Y, and Z-axis are with anti-collision devices. It can effectively prevent operation out of control. Complete dual protection function with the soft and hard limit. Ensure the safe operation of injection molding machine and travel robot. The design of I / O short-circuits protection can effectively prevent the circuit board from damage due to an electrical short circuit.
- Intelligence
7.0 inch high definition TFT touch screen. The USB can be used to upgrade the manual controller and main-board, download program data, and the open program teaching, 8GB memory, and independent dual 16-bit IO expansion board can expand up to 4 IO boards. The hardware used multi-layer PCB and multi-rank high precision electrical modular, strong anti - interference ability. Hardware protect function, each signal output with intelligent detection, avoid short-circuit, overload and high temperature. Base on the VARAN BUS technology, the system can be extended, strong adaptability and flexibility. Teach modules with stacking and matrix locate functions, support conditional judgment, loop control, signal waiting and others logic instructions.
- User Friendly
Multi-languages system and reserved auxiliary equipment slots able to support our global clients' need.

■ Application

The ST3-S2 series robot is designed for rapid and precise removal of products from injection molding machine, and place them at desired locations. Apply to 2-plate mold or hot runner system. Capable of arranging, stacking, quality checking and in mold placement. Suitable for injection molding machine with clamping force under 3600 tons.

ST3-S Series

Outline Drawings

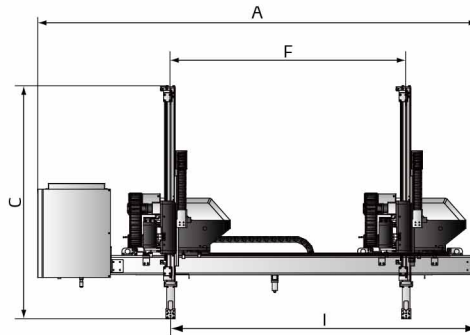
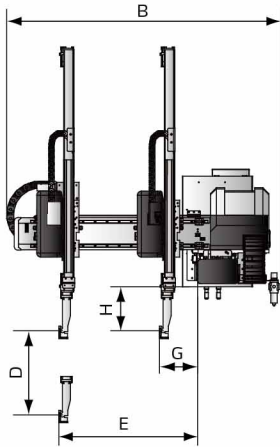

3-axis servo with single kick-stroke beam

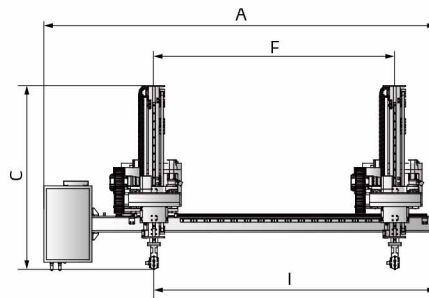
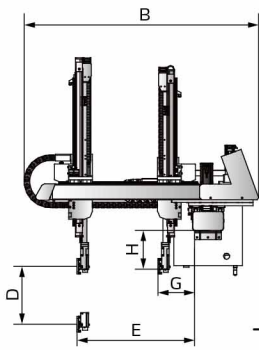

Three Axes Servo Telescopic (Stationary-beam type)

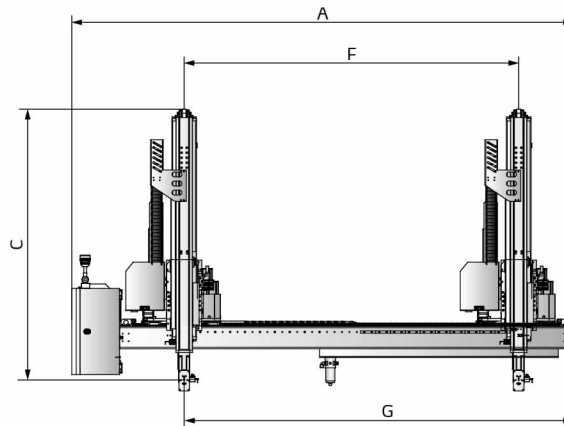
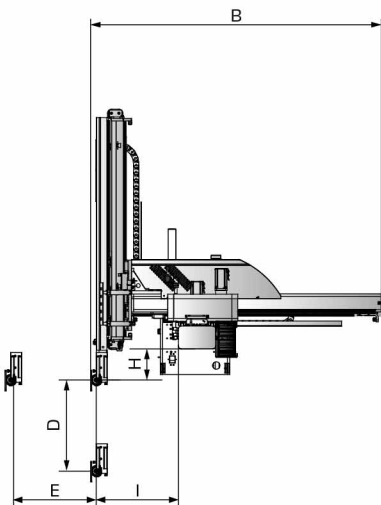

Three Axes Servo Telescopic (Movable-beam type)

■ Specifications

Model(ST3)	700-1200-S2	700-1400-S2	900-1600T-S2	1100-1800T-S2	1300-1800T-S2	950-1400HT-S2	1100-1600HT-S2	
Robot Type	Single kick stroke beam			Telescopic arm with frame type beam				
IMM (ton)	50~80	80-160	220-260	320-400	400-500	160~220	220~260	
Traverse Stroke (mm)	1200	1400	1600	1800	1800	1400	1600	
Crosswise Stroke (mm)	470	470	525	680	680	560	680	
Vertical Stroke (mm)	700	700(800)	900(1000)	1100(1200)	1300	950	1100	
Max Load (with tool) (kg)	3	3	5	8	8	5	5	
Min Pick-out Time (sec)	1.3	1.3	1.3	1.5	2	1	1.2	
Min Cycle Time (sec)	5.2	5.2	5.5	6.2	8	3.9	4.2	
Air Pressure (bar)	4~6	4~6	4~6	4~6	4~6	4~6	4~6	
Max. Air Consumption (Nl/cycle)*	4	4	4	6	6	6	6	
Integrated PLC unit and Drives	●	●	●	●	●	-	-	
Weight (kg)	230	240	270	320	400	340	390	
Dimensions (mm)	A	2230	2560	2840	3000	3000	2640	2840
	B	1200	1350	1465	1530	1530	1410	1530
	C	1510	1420(1520)	1330(1350)	1390(1445)	1490	1335	1390
	D	700	700(800)	900(1000)	1100(1200)	1300	950	1100
	E	610	610	720	950	950	830	950
	F	1200	1400	1600	1800	1800	1400	1600
	G	155	155	155	190	190	190	190
	H	210	240	240	230	230	230	230
	I	1580	1820	2020	2150	2150	1750	1950

- Notes: 1) "M" stands for middle mold detector. (suitable for three-plate mold.)
 "EM12" stands for EUROMAP 12 communication interface.
 "EM67" stands for EUROMAP 12 communication interface.
 "ABS" at the end of the model code stands for models of high precision.
 "N" stands for non-operation side, operation side without "N"
- 2) Power supply: 1Φ, 200~240V, 50/60Hz.
 3) " * " Max. air consumption for vacuum device 60Nl/min.
 4) () means option
 5) "●" means: option, and add "I" at the model code, and "-" means: unavailable

ST3-S Series

Specifications

Model(ST3)	950-1400MHT-S2	1100-1600MHT-S2	1400-2000MT-S	1600-2200MT-S	1800-2400MT-S	2000-2800MT-S	
Robot Type	Small movable-beam type	Small movable-beam type	Medium movable-beam type	Medium movable-beam type	Medium movable-beam type	Medium movable-beam type	
IMM (ton)	160-220	220-260	450-650	650-850	850-1400	1400-1800	
Traverse Stroke (mm)	1400	1600	2000	2200	2400	2800	
Crosswise Stroke (mm)	650	650	900	1000	1200	1200	
Vertical Stroke (mm)	950	1100	1400	1600	1800	2000	
Max Load (with tool) (kg)	5	5	10	20	20	20	
Min Pick-out Time (sec)	1.3	1.3	3	3.3	3.6	3.8	
Min Cycle Time (sec)	4	4	13	14	16	17.5	
Air Pressure (bar)	4~6	4~6	4~6	4~6	4~6	4~6	
Max. Air Consumption (Nl/cycle)*	4	4	6	6	6	6	
Weight (kg)	430	450	530	580	650	690	
Dimensions (mm)	A	2600	2800	3160	3460	3660	3860
	B	1380	1380	1717	2000	2200	2200
	C	1340	1400	1890	2100	2200	2300
	D	950	1100	1400	1600	1800	2000
	E	650	650	1255	1355	1555	1555
	F	1400	1600	2000	2200	2400	2800
	G	2000	2200	2450	2650	2850	3250
	H	180	180	260	260	260	260
	I	230	230	355	355	355	355

- Notes: 1) "M" stands for middle mold detector. (suitable for three-plate mold.)
 "EM12" stands for EUROMAP 12 communication interface.
 "EM67" stands for EUROMAP 12 communication interface.
 "ABS" at the end of the model code stands for models of high precision.
 "N" stands for non-operation side, operation side without "N"
- 2) Power supply: 1Φ, 200~240V, 50/60Hz.
- 3) " * " Max. air consumption for vacuum device 60Nl/min.

■ Specifications

Model(ST3)	2200-3000LT-S	2600-4000LT-S	3000-4000LT-S	
Robot Type	Large movable-beam type	Large movable-beam type	Large movable-beam type	
IMM (ton)	1800~2400	2400~3000	3000~3600	
Traverse Stroke (mm)	3000	4000	4000	
Crosswise Stroke (mm)	1500	1660	1820	
Vertical Stroke (mm)	2200	2600	3000	
Max Load (with tool) (kg)	40	40	40	
Min Pick-out Time (sec)	4.2	4.5	5.0	
Min Cycle Time (sec)	24	26	28	
Air Pressure (bar)	4~6	4~6	4~6	
Max. Air Consumption (NI/cycle)*	8	8	8	
Weight (kg)	990	1010	1080	
Dimensions (mm)	A	4500	5500	5500
	B	2650	2820	2980
	C	2600	2800	3000
	D	2200	2600	3000
	E	1900	2050	2250
	F	3000	4000	4000
	G	3500	4500	4500
	H	350	350	350
	I	320	320	320

- Notes: 1) "M" stands for middle mold detector. (suitable for three-plate mold.)
 "EM12" stands for EUROMAP 12 communication interface.
 "EM67" stands for EUROMAP 12 communication interface.
 "ABS" at the end of the model code stands for models of high precision.
 "N" stands for non-operation side, operation side without "N"
 2) Power supply: 1Φ, 200~240V, 50/60Hz.
 3) " * " Max. air consumption for vacuum device 60NI/min.

Shini Group

Addr: No. 23, Minhe St., Shulin Dist.,
New Taipei, Taiwan

Tel: +886 2 2680 9119

Fax: +886 2 2680 9229

Email: shini@shini.com

Factories:

- Taiwan
- Dongguan
- Pinghu
- Ningbo
- Chongqing
- Pune

2021-01-15-04 Copyrights Reserved.

www.shini.com