

Venturi Loader

VL-100



Refer carefully to the manual before operation.

VL Series

■ Coding Principle

VL - xx

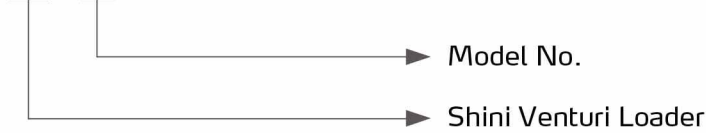

■ Features

- Light-weight and compact design.
- Exhaust air filter to reduce dust output.
- Silent operation, it uses high-pressure air to convey materials.
- Capacitive sensor mounted on the glass-tube for accurate level monitoring.
- Compressed air filter and regulator to eliminate moisture and maintain stable air pressure.
- Easy access to material hopper for convenient cleaning.



VL-50



Filter and Control Units

■ Application

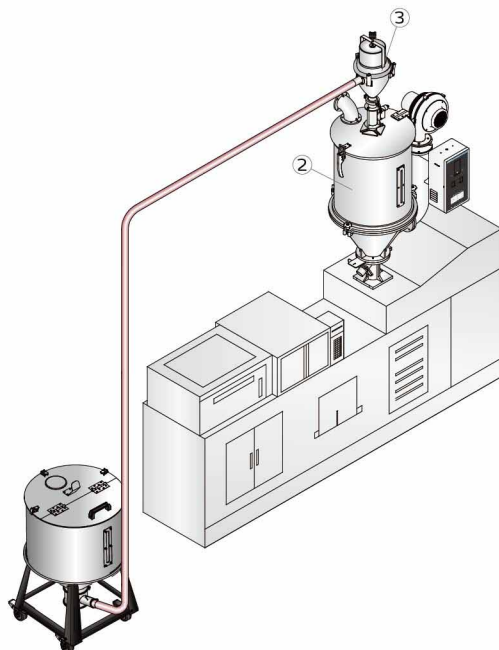

1. Material storage tank
2. Hopper dryer
3. Venturi loaders
4. Master batch doser

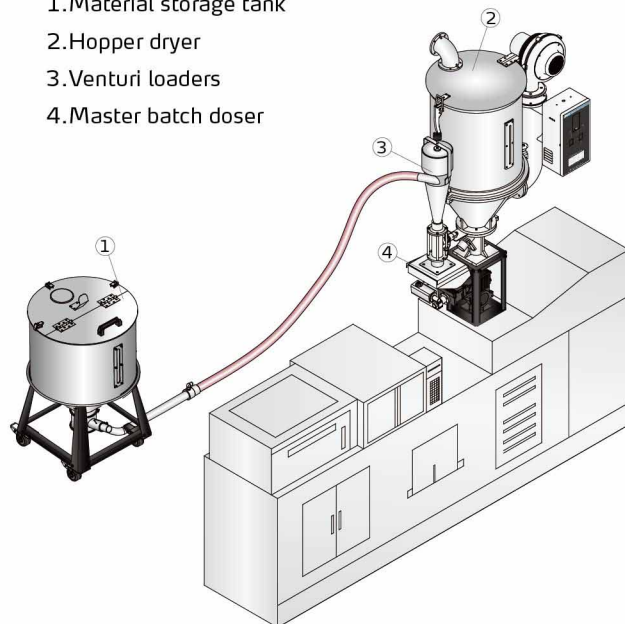

Structure

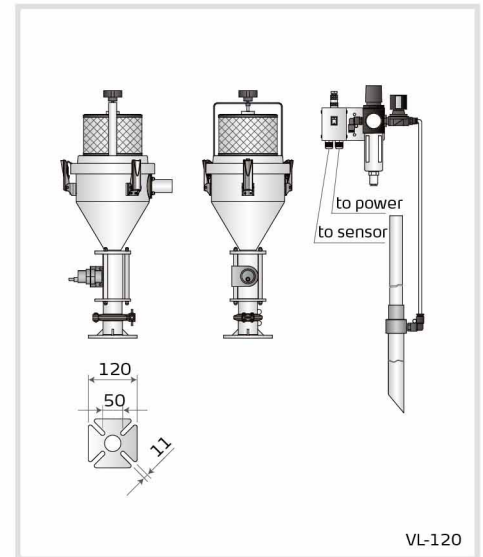
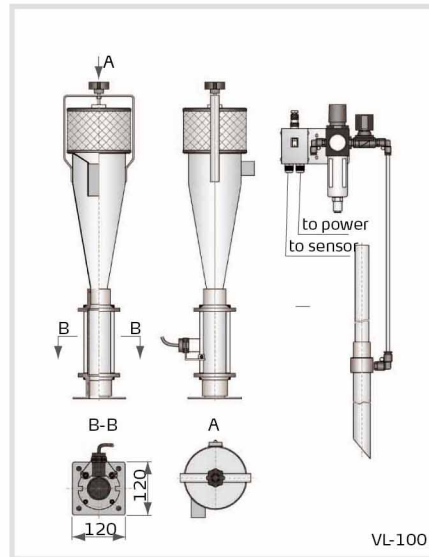
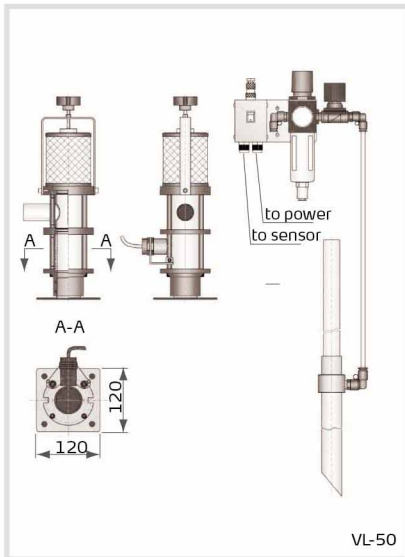

Specifications

Model		VL-50	VL-100	VL-120
Conveying Capacity	kg/hr	40	60	80
	lb/hr	88	132	176
Material Hopper	L	0.5	2.8	3
	gal	0.13	0.74	0.79
Air Flow	L/hr	6,000	6,000	6,000
	gal/hr	1,585	1,585	1,585
Compressed Air (kgf/cm ²)		6.0	6.0	6.0
Max. conveying distance	m	6	6	6
	inch	236	236	236
Conveying Pipe (inch)		1.25	1.25	1.25
Length (L)	mm	900	900	900
	inch	35	35	35
Dimension (H×W×D)	mm	380 × 145 × 150	720 × 165 × 160	630 × 240 × 280
	inch	15 × 5.7 × 5.9	28.3 × 6.5 × 6.3	24.8 × 9.4 × 11
Weight	kg	4.5	7	7.5
	lb	9.9	15.4	16.5

Notes: 1) Test condition of conveying capacity: Plastic material of bulk density 0.8kg/L(6.7lb/gal), dia. 3~5 mm/0.12~0.2inch, vertical conveying height: 2m/79inch, horizontal conveying distance: 1m/39inch.

2) Power supply 1Φ, 115/230V, 50/60Hz.

We reserve the right to change specifications without prior notice.