

SIC-W-R2

CFC-free Refrigerant Water-cooled Water Chiller

Date: May 2026

Version: Ver. J



Contents

1. General Description	5
1.1 Coding Principle	6
1.2 Main Features	6
1.3 Accessory Option	7
1.4 Safety Regulation	9
1.4.1 Safety Regulations	9
1.4.2 Signs and Labels.....	10
1.5 Exemption Clause	11
2. Structural Features and Working Principle.....	12
2.1 Main Function.....	12
2.1.1 Working Principle	12
2.2 Main Components and Function.....	13
2.2.1 Compressor.....	13
2.2.2 Fin-style Condenser	13
2.2.3 Drying Filter.....	14
2.2.4 Thermal Expansion Valve	14
2.2.5 Evaporator.....	15
2.2.6 High and Low Pressure Sensor.....	15
2.2.7 Refrigerant Indicator (Option).....	16
2.2.8 Liquid Pipe Solenoid Valve (option)	16
2.2.9 Hot-gas By-pass Valve.....	17
2.2.10 Single-way pressure release valve.....	17
2.2.11 Disk Filter	17
(Customers need to install it at the return chilled water outlet by themselves)	18
2.2.12 Flow Switch	18
2.2.13 Water Tank Refrigerant Indicator	18
3. Installation and Debugging.....	20
3.1 Machine Positioning	20
3.2 Power Connection	20
3.3 Installation Diagram.....	21

4. Application and Operation.....	22
4.1 Startup Steps.....	22
4.2 Shutdown Steps	22
4.3 Panel Description	23
4.3.1 Common Interface.....	23
4.3.2 Operation Menu Interface.....	27
4.3.3 User Menu.....	32
5. Troubleshooting	35
6. Repair and Maintenance	39
6.1 Components Maintenance.....	40
6.1.1 Condenser.....	40
6.1.2 Evaporator.....	40
6.1.3 Disk Filter	41
6.2 Maintenance Schedule	41
6.2.1 About the Machine	42
6.2.2 Check after Installation.....	42
6.2.3 Daily Checking	42
6.2.4 Weekly Checking	42
6.2.5 Monthly Checking.....	42
6.2.6 Tri-monthly Checking	42
6.2.7 Half-yearly Checking	43
6.2.8 Yearly Checking	43
6.2.9 3-year Checking	43

Table Index

Table 4-1: Main Interface Description.....	23
Table 4-2: Running Interface Description	25
Table 4-3: Current Fault Inquiry Interface Description.....	26
Table 4-4: User Menu Description	32

Picture Index

Picture 1-1: SIC-W-R2.....	5
----------------------------	---

Picture 2-1: Working Principle	12
Picture 2-2: Compressor.....	13
Picture 2-3: Tube-in-shell Condenser.....	14
Picture 2-4: Drying filter	14
Picture 2-5: Thermal Expansion Valve	15
Picture 2-6: Evaporator.....	15
Picture 2-7: High and Low Pressure Sensor.....	16
Picture 2-8: Refrigerant Indicator.....	16
Picture 2-9: Liquid Pipe Solenoid Valve.....	16
Picture 2-10: Hot-gas By-pass Valve.....	17
Picture 2-11: Single-way pressure release valve.....	17
Picture 2-12: Disk Filter	18
Picture 2-13: Flow Switch	18
Picture 2-14: Refrigerant Indicator.....	19
Picture 3-1: Machine Installation Location	21
Picture 4-1: Startup Step	22
Picture 4-2: Shutdown Steps	23
Picture 4-3: Main Interface	23
Picture 4-4: Running Interface.....	25
Picture 4-5: Data Inquiry Screen	26
Picture 4-6: Current Fault Inquiry Screen	26
Picture 4-7: Historical Fault Inquiry Interface.....	27
Picture 4-8: Operation Menu Interface.....	28
Picture 4-9: General Setting Interface	28
Picture 4-10: User Setting Interface.....	28
Picture 4-11: Comm. Setting (option) Interface	29
Picture 4-12: Backlight Time Interface.....	29
Picture 4-13: Language Setting Screen.....	30
Picture 4-14: Clock and One-Week Timer Interface	30
Picture 4-15: Data Download Interface.....	31
Picture 4-16: Temp. Data Download Interface.....	31
Picture 4-17: Alarm Record Download Interface	32

1. General Description



Read this manual carefully before operation to prevent damage of the machine or personal injuries.

SIC-W-R2 series of water-cooled water chiller adopts water tower cooling method, and has compressor overheat protector, pump overload protector, phase reverse and shortage alarm, anti-freezing protector, and high and low pressure switch protector to ensure stable machine performance and long service life. It can cool down quickly and control the temperature stably, and the RS485 communication interface can meet the customer's demands. This series of product mainly uses the heating and cooling exchange principle to work, which is suitable for cooling in modern industry and is an indispensable in the application.



Picture 1-1: SIC-W-R2

1.1 Coding Principle

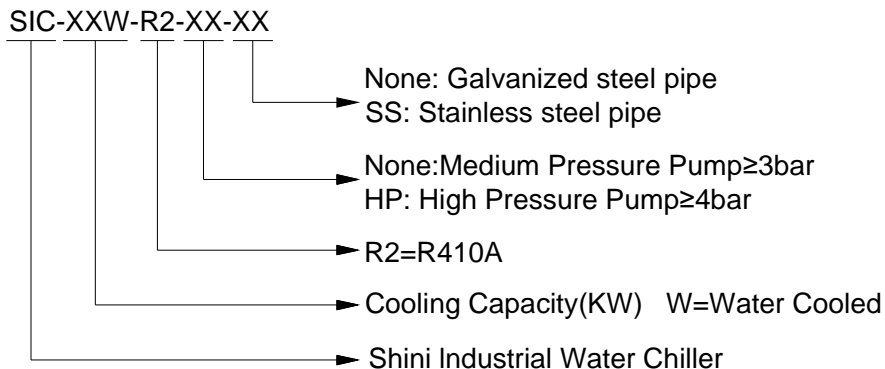

1.2 Main Features

- 1) Cooling range 7~25°C;
- 2) R410A ozone-friendly refrigerant with a high efficient cooling result;
- 3) Plate evaporator ensures efficient heat exchanging, with a anti-icing device;
- 4) A well-known compressor that ensures low noise, energy-efficient, and long service life;
- 5) The refrigerating system has high and low pressure transmitter to read the system pressure accurately for better control and protection;
- 6) Circular stainless steel thermal insulated water tank, and unique cyclone design thermal insulated water in stainless for even distribution of chilling water;
- 7) Adopt high precision temperature controller with a display precision of ± 0.1 °C;
- 8) It has a hot-gas bypass valve with a control accuracy of up to ± 0.1 °C;
- 9) The water loop equipped with return water filter, with galvanized pipes that can extend the service life effectively;
- 10) The inlet and outlet pipe adopt an adaptive bypass valve to ensure stable outlet water pressure.
- 11) Equipped with a flow switch to avoid the unit from operation without water flow;
- 12) The standard water tank level indicator for visualizing check of the water level;

- 13) Compact outline and small foot;
- 14) RS485 communication interface to realize centralized monitoring;
- 15) The controller adopts 4.3" touch panel, with human-machine interface for easy operation;
- 16) Standard equipped with flow display reference value;
- 17) Equipped with USB interface to record data in real time and back up local data.

1.3 Accessory Option

- 1) High pressure pumps (about 4kgf /cm²) are optional to meet any pressure requirements.
- 2) Level sensor is optional to detect whether the water level is normal in the water tank;
- 3) The liquid pipe solenoid valve is opted to cut off the liquid and gas refrigerant pipeline during shutdown as to reduce the liquid hammer risks;
- 4) Level sensor can be opted to detect the refrigerant and ensure its quality and water ratio.
- 5) Stainless steel pipeline can be optional for effective improving the service life.
- 6) High-precision flow sensor can be optional for precise monitoring of medium flow data.
- 7) Environmental temperature thermocouple can be optional for real-time collecting environment temperature.
- 8) The Ethernet communication interface can be optional for convenient networking with remote equipment.
- 9) The water pressure sensor is optional for real-time monitoring the water pipe pressure.



All service work should be carried out by a person with technical training or corresponding professional experience. The manual contains instructions for both handling and servicing. Chapter 6, which contains service instructions intended for service engineers. Other chapters contain instructions for the daily operator.

Any modifications of the machine must be approved by SHINI in order to avoid personal injury and damage to machine. We shall not be liable for any damage caused by unauthorized change of the machine.

Our company provides excellent after-sales service. Should you have any problem during using the machine, please contact the company or the local vendor.

Shini Hotline Service:

Headquarter and Taipei factory:

Tel: + 886 (0)2 2680 9119

Shini Plastics Technologies (Dongguan), Inc.:

Tel: +86 (0)769 8331 3588

Shini Plastics Technologies (Pinghu), Inc.:

Tel: +86 (0)573 8522 5288

Shinden Precision Machinery (Chongqing), Inc.:

+86 (0)23 6431 0898

1.4 Safety Regulation

The user must conform to the following safety rules when operating the machine.

1.4.1 Safety Regulations



Attention!

Installation of the device is allowed only to the professional electrician.
Before maintaining and repairing the device, be sure to turn off the main switch and control switch.



Warning!

High Voltage!

This label is posted on enclosure of the electrical control cabinet!



Warning!

Be careful!

Pay more attentions at the places where this sign is attached!



Attention!











Drain the water inside when power off at the cold day to avoid freezing!

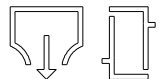

Attention!

No need for regular inspection because all the electrical parts in the control unit are fixed tightly!

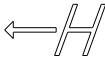
1.4.2 Signs and Labels

	<p>Pump pressure gauge: display actual pressure of cold water system.</p>
	<p>Cold water return port (return from the mould)</p>
	<p>Cold water outlet (to mold)</p>
	<p>Cooling water inlet</p>
	<p>Cooling water outlet</p>
	<p>Purified water filling port</p>
	<p>Water tank discharge port</p>
	<p>Plate exchanger discharge port</p>
	<p>Water discharge port</p>
	<p>Overflow port</p>
	<p>Water tank high level indicator</p>
	<p>Water tank low level indicator</p>

1.5 Exemption Clause

The following statements clarify the responsibilities and regulations born by any buyer or user who purchases products and accessories from Shini (including employees and agents).

Shini is exempted from liability for any costs, fees, claims and losses caused by reasons below:

- 1) Any careless or man-made installations, operation and maintenances upon machines without referring to the Manual prior to machine using.
- 2) Any incidents beyond human reasonable controls, which include man-made vicious or deliberate damages or abnormal power, and machine faults caused by irresistible natural disasters including fire, flood, storm and earthquake.
- 3) Any operational actions that are not authorized by Shini upon machine, including adding or replacing accessories, dismantling, delivering or repairing.
- 4) Employing consumables or oil media that are not appointed by Shini.

2. Structural Features and Working Principle

2.1 Main Function

SIC-W-R2 water-cooled water chiller mainly comprised of the compressor, condenser, thermal expansion valve and the evaporator, which transforms from gas or liquid refrigerant by water tower cooling, and adopts heat absorbing and releasing to achieve the refrigerating effect.

2.1.1 Working Principle

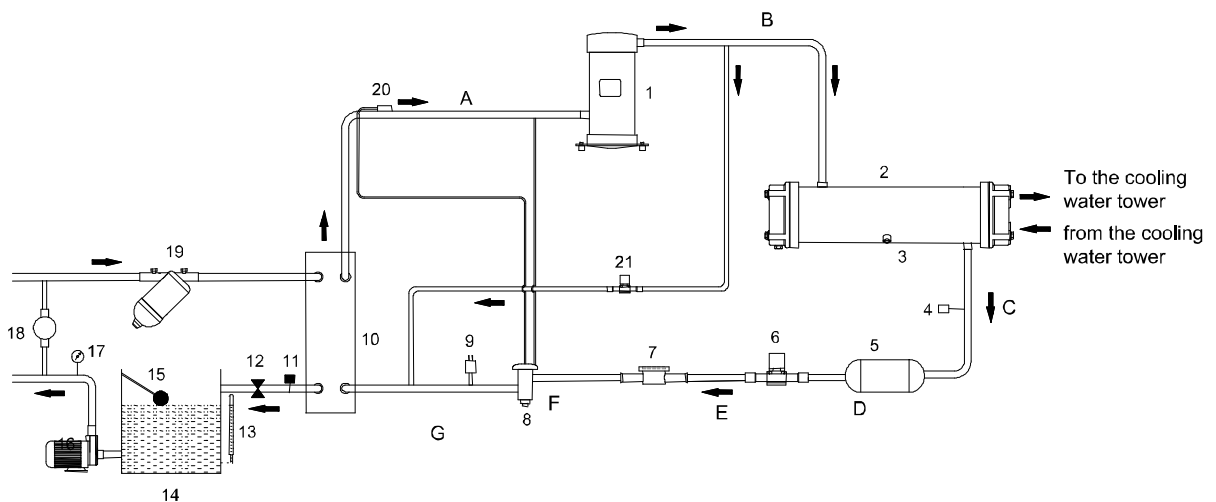

- | | | |
|----------------------------|----------------------------------|--|
| 1.Compressor | 2. Shell and tube condenser | 3. Fusible plug |
| 4. High pressure monitor | 5. Drying filter | 6. Liquid pipe solenoid valve (option) |
| 7. Liquid indicator | 8. Expansion valve | 9.Low pressure transmitter |
| (option) | | |
| 10. Plate evaporator | 11.Flow switch | 12. Flow adjusting ball valve |
| 13.Water tank level sensor | 14.Water tank | 15.Float ball switch |
| 16.Pump | 17.Water pressure gauge | 18.Bypass valve |
| 19. Disc filter | 20. Expansion valve thermocouple | 21. Hot gas bypass valve |

Picture 2-1: Working Principle

After the water-cooled water chiller SIC-W-R2 is powered on, click the switch to



status firstly, and then start the compressor 1 after water system circulation.

The compressor 1 starts to work, the solenoid valve 7 opens, and the refrigerant changes the low-temp. and low-pressure gas into high-temp. and high-pressure gas under the action of compressor 1, which enters the condenser 2 in the BC direction. Under the action of cooling water circulation, it will accelerate heat exchange with the water, and the refrigerant is changed from gaseous state to liquid state, meanwhile the heat is taken away by the air; In the C-D-E-F process, the liquid refrigerant from the condenser 3 passes through the drying filter 5, which is reached the expansion valve 8 through the liquid pipe solenoid valve 6 and liquid indicator 7 after drying and impurities filtering. In the F-G process, the high-pressure liquid refrigerant is depressurized by the thermal expansion valve 8 to decrease the temperature. In the G-A process, the low temp. and low-pressure refrigerant exchanges heat with the chilled water through the evaporator 10 to make chilled water reach the set temp.; The low-temp. gas refrigerant from the evaporator 10 will return to the compressor 1, and so on.

2.2 Main Components and Function

2.2.1 Compressor

- 1) The low temp. and low pressure refrigerant air that sucked by the compressor, and the high temp. and high pressure refrigerant gas that discharged through the copper outlet pipe is the heart of the refrigerant system.
- 2) Our company uses the Copeland scroll compressor.



Picture 2-2: Compressor

2.2.2 Fin-style Condenser

- 1) It is the component to discharge the heat. The refrigerant absorbs the heat and discharges it through the condenser.
- 2) Our company's air-cooled water chiller uses the female thread fin-style condenser.



Picture 2-3: Tube-in-shell Condenser

2.2.3 Drying Filter

- 1) Drying filter's function: Remove impurities in the refrigerant, absorb the free moisture in the refrigerant, and prevent blockage at the narrow section of the pipeline (especially at the valve port of thermal expansion valve).
- 2) The filter size is usually opted according to the water chiller's refrigerating capacity and refrigerant pipe diameter.
- 3) It is set in front of thermal expansion valve and liquid pipe solenoid valve.



Picture 2-4: Drying filter

2.2.4 Thermal Expansion Valve

- 1) The thermal expansion valve throttles and depressurizes the refrigerant and regulates the refrigerant flow into the evaporator.
- 2) Install in front of the evaporator.



Picture 2-5: Thermal Expansion Valve

2.2.5 Evaporator

- 1) Evaporator (plate exchange) is a device that outputs the refrigerating capacity. The refrigerant absorbs the water heat in the evaporator to achieve the refrigerating purpose.
- 2) Adopt plate evaporator that largely improves the heat transfer efficiency.



Picture 2-6: Evaporator

2.2.6 High and Low Pressure Sensor

- 1) The high and low pressure sensors are used to detect the working pressure of the compressor's suction air inlet and outlet.
- 2) It breaks when the high pressure is set as 4.0MPa, and it closes when the pressure is 2.5MPa; It breaks when the low pressure is 0.4MPa, and it closes when the pressure is 0.6MPa.
- 3) When the side high pressure is higher than 4.0Mpa, or the side low pressure is lower than 0.4MPa, the controller will alarm and the machine will stop running.



Picture 2-7: High and Low Pressure Sensor

2.2.7 Refrigerant Indicator (Option)



Picture 2-8: Refrigerant Indicator

- 1) Used to observe the refrigerant state at this position;
- 2) Used to observe the water content of the system;
- 3) Install in front of the expansion valve;

2.2.8 Liquid Pipe Solenoid Valve (option)



Picture 2-9: Liquid Pipe Solenoid Valve

- 1) Cut off the refrigerant circuit immediately after the machine stops.
- 2) Install in front of the expansion valve

2.2.9 Hot-gas By-pass Valve



Picture 2-10: Hot-gas By-pass Valve

- 1) Used to by-pass the refrigerant gas when it gets close to the set temperature as to avoid compressor frequent start and achieve accurate temperature control;
- 2) Install on the connecting pipe between the compressor outlet and expansion valve outlet.

2.2.10 Single-way pressure release valve



Picture 2-11: Single-way pressure release valve

The single-way pressure release valve works through the spring force; When the system pressure is smaller than the set pressure, the diaphragm will block the pipeline under the action of spring force; When the system pressure is greater than the set pressure, the diaphragm compresses the spring, the pipeline is connected, and the liquid passes through the pressure release valve.

2.2.11 Disk Filter

(Customers need to install it at the return chilled water outlet by themselves)



Picture 2-12: Disk Filter

The disk filter is composed of the valve core and valve body. When filtering, press the disk tightly, the water flows through the disk, and the impurities are kept out of the disk or between the grooves, thus achieving the filtering purpose. The disk filter has deep filtering function and excellent blocking function, which features easy operation and maintenance.

2.2.12 Flow Switch



Picture 2-13: Flow Switch

- 1) The flow switch can be used to check whether the chilled water flow is sufficient.
- 2) Install on the water pipeline between the evaporator and water tank.

2.2.13 Water Tank Refrigerant Indicator



Picture 2-14: Refrigerant Indicator

Through the water tank refrigerant indicator, it can check whether the water level in the water is in normal range.

3. Installation and Debugging

Note:

Before installation, please read this chapter carefully and install according to the procedures as follows!

3.1 Machine Positioning

- 1) When installing the machine, make sure to leave enough space for installation (reserve at least 500mm around the machine). It is inconvenient for machine operation, inspection and maintenance when it is installed in a narrow space.
- 2) Don't set on the machine or place objects on it.
- 3) Keep the machine away flammable and explosive goods.

3.2 Power Connection

- 1) Make sure the voltage and frequency of the power source comply with those indicated on the manufacturer nameplate that attached to the machine.
- 2) Power cable and earth connection should conform to your local regulations.
- 3) Use independent electrical wires and power switch. Diameter of electrical wire should not be less than those used in the control box.
- 4) The power cable connection terminals should be tightened securely.
- 5) The machine requires 3-phase 4-wire power source, connect the power lead (L1, L2, L3) to the live wires, and the earth (PE) to the ground.
- 6) Power supply requirements:
Main power voltage: +/- 5%
Main power frequency: +/- 2%
- 7) ***Please refer to electrical drawing of each model to get the detailed power supply specifications***



Power connection must be conducted by professional electricians!

Do not change the circuit of the water chiller without our company's authority. If the machine is damaged by unauthorized change we are not responsible for this.

3.3 Installation Diagram

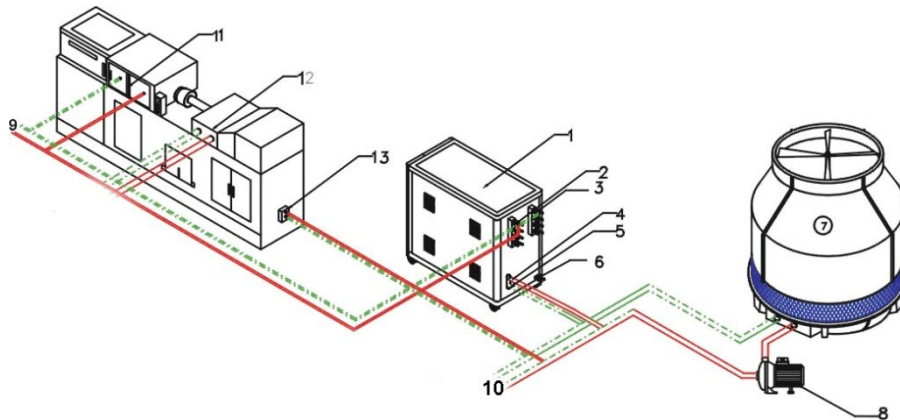

Names of Parts:

- | | | |
|-------------------------------|-------------------------|------------------------------|
| 1. Water chiller | 2. Chilled water outlet | 3. Chilled water inlet |
| 4. Cooling water outlet | 5. Cooling water inlet | 6. Drainage port |
| 7. Cooling water tower | 8. Cooling water pump | 9. Chilled water circulation |
| 10. Cooling water circulation | 11. Mould cooling | 12. Cooling barrel |
| 13. Oil cooling | | |

Picture 3-1: Machine Installation Location

Notices for Installation:

- 1) Install the pipe system according to the wiring diagram, and take insulation measures of the chilled water pipes with thermal insulated materials.
- 2) Install the drain valve at the lowest point of the chilled water circulating system.
- 3) Customers need to install the laminated filter at the return chilled water outlet of the chiller by themselves.
- 4) As the water source quality is poor, it must clean the filter in the chilled water loop regularly.
- 5) Install the pipes and test is for leakage. The chilled water loop must be covered with insulation layer to avoid refrigerant losses and pipe drips.

4. Application and Operation

4.1 Startup Steps

- 1) Turn on the main power switch to "ON".



Open

Picture 4-1: Startup Step

- 2) Turn the switch to  status.



Notes

The running direction of the pump must be correct.



Notes

Please confirm to start the chilled water pump before startup; Check the water tank of the chiller, and don't operate the system without water. Otherwise, our company will not be responsible for the machine damage.



Notes

In order to reduce the damage to the machine and prolong its life span, please start the machine according to the correct steps.



Note

The compressor can't be started frequently due to its characteristics (frequent start and stop will affect the service life), so the compressor will delay 3 mins. before its start after turned on the pump. The temperature controller parameters have been set, which shall not be adjusted freely.

4.2 Shutdown Steps

- 1) Turn the switch to  status.
- 2) Turn the main power switch to OFF.



OFF

Picture 4-2: Shutdown Steps



Note

When the main power switch is at ON position, please be careful of the electric shock hazard.



Note

In order to reduce the damage to the machine and prolong its life span, please turn off the machine according to the correct steps.

4.3 Panel Description

4.3.1 Common Interface

Common interfaces include the main interface and alarm interface.





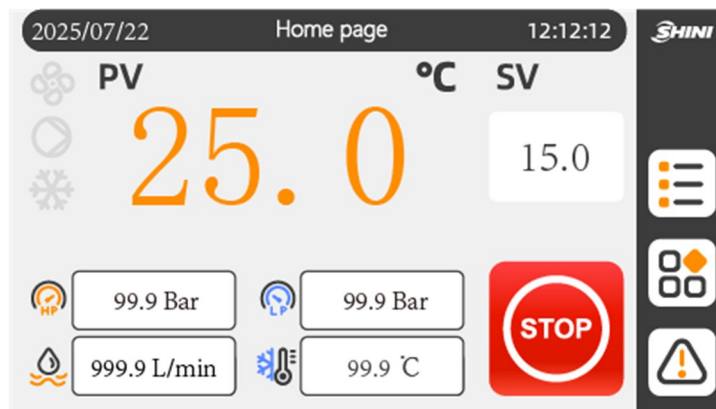



4.3.1.1 Main Interface

After countdown, it will enter main interface, which displays as follows:



Picture 4-3: Main Interface

Table 4-1: Main Interface Description

Press Keys	Key Name	Key Function	Description
	Data query interface button	Enter the data query interface	Click to enter the button query interface, where user can inquire information such as temperature, pressure, flow rate, pump current, and cumulative operating time.
	Operation menu button	Enter the operation menu interface	
	Fault query button	Query fault info.	<p>1. When the system breaks down, it will flash on the main interface.</p> <p>2. Click to enter the current fault information query interface.</p> <p>3. After entering the query interface, click on the  icon to search for historical fault information.</p>
 	Power On/Off button	Unit start and stop	 Run status  Standby status
	SV zone button	Modify the set temperature (keyboard input form)	Only when the【Lock Temp.】is set to 'No', this button can be clicked to modify the set temperature.

4.3.1.2 Running Interface

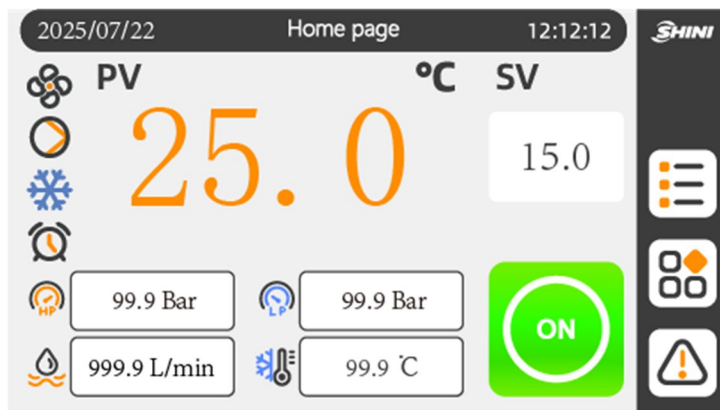

Picture 4-4: Running Interface

Table 4-2: Running Interface Description

Icons	Icon Name	Description
	pump running	This icon indicates that the pump is running.
	compressor cooling	This icon indicates that the compressor is turned on and cooling is in progress.
	blower running	This icon indicates that the blower is running.
	timing	This icon indicates that the timer function is enabled. It can click to enter the clock interface and modify the timer settings.
99.9 Bar 99.9 Bar 999.9 L/min 99.9 °C	pressure, flow, anti-freeze temperature display box	means compressor high pressure, means compressor low pressure, means water pressure value, means flow rate value, and means anti-freeze temperature. The relevant data will only be displayed when the corresponding sensors and temperature probes are selected for use; When the water pressure sensor is disabled, if the anti-freeze temperature probe is selected for use, the antifreeze temperature will be displayed.

4.3.1.3 Inquiry Interface

1) Data Inquiry



Press the  button on the main interface to enter the following data query interface.

2025/07/22		query		12:12:12		SHINI	
icon	name	value	uint				
	Water Temp	25.0	°C				
	Antif Temp	5.0	°C				
	High Pressure 1	99.9	Bar				
	Low Pressure 1	99.9	Bar				
	Water Pressure	99.9	Bar				
	Flow	999.9	L/min				
	Pump current	0.0	A				
	Comp Runtime	1	min				

Picture 4-5: Data Inquiry Screen

Check all current probe temperature, pressure, flow rate, pump current, compressor accumulative run time, and other data in the system.

2) Current Fault Inquiry









When the unit breaks down, the  will flash on the main interface, and click silencer to enter the interface as below:

2025/07/22		Errors		12:12:12		SHINI	
Number	Alarm content						
1	HP Sensor Break						

Picture 4-6: Current Fault Inquiry Screen

Table 4-3: Current Fault Inquiry Interface Description

Press Key	Key Name	Description
	Fault reset	After troubleshooting, press the key to reset the fault.

	Silencer	Clear the system alarm sound
	Return to the home page	/
	Back to previous level	/
	Page up	Page up to query fault information, the gray icon can not be pressed, and green icon can be pressed.
	Page down	Page down to query fault information, the gray icon can not be pressed, and green icon can be pressed.
	Historical fault query interface jump key	Click to jump to the historical fault information inquiry interface.
	Version number query key	Click to jump to the version number information inquiry interface.

3) Historical Fault Inquiry

Press the  button on current fault interface to enter the following historical fault information inquiry interface:

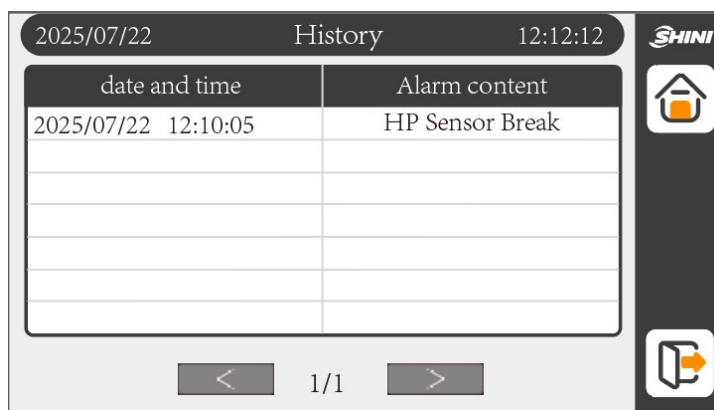

Picture 4-7: Historical Fault Inquiry Interface

4.3.2 Operation Menu Interface



Picture 4-8: Operation Menu Interface

4.3.2.1 General Setting Interface



Picture 4-9: General Setting Interface

1) User Setting

Set user parameters, and refer to the **<User Menu>** chapter for the details of each parameter.

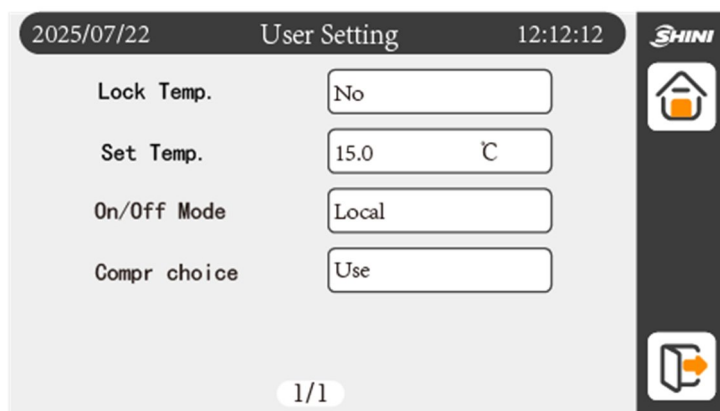

Picture 4-10: User Setting Interface

2) Communication Setting (Option)

Ethernet related parameters can only be queried when the manufacturer **【Ethernet selection】** is set to "use".

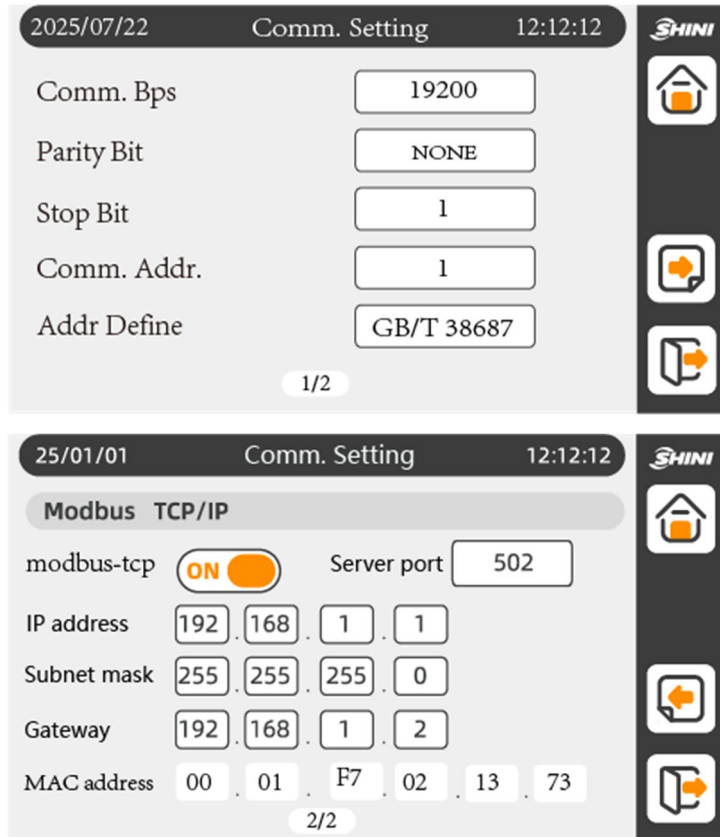

Picture 4-11: Comm. Setting (option) Interface

3) Backlight Time

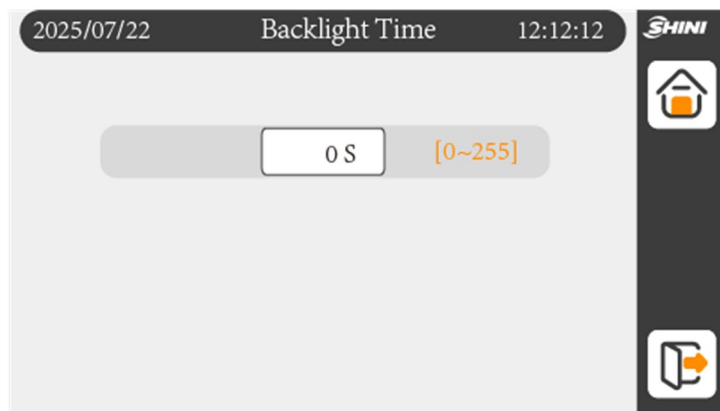

Picture 4-12: Backlight Time Interface

Set backlight time: setting range: 0~255 secs.

4.3.2.2 Language Setting



Picture 4-13: Language Setting Screen

4.3.2.3 Clock and One-Week Timer

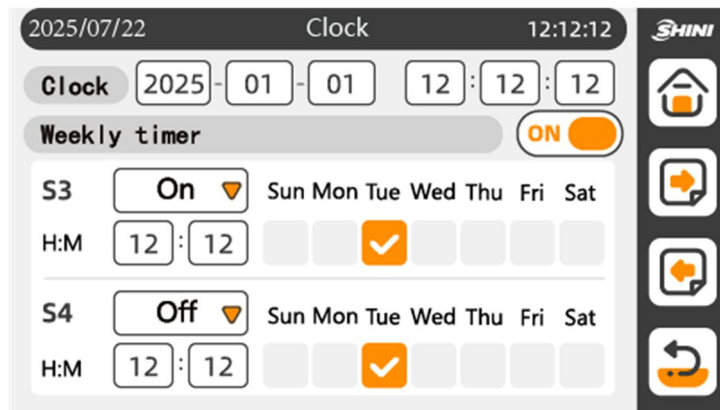

Picture 4-14: Clock and One-Week Timer Interface

Set the system clock and one week timer On/Off function. Timing main switch

: used to select where to enable timing On/Off function.

4.3.2.4 Data Download

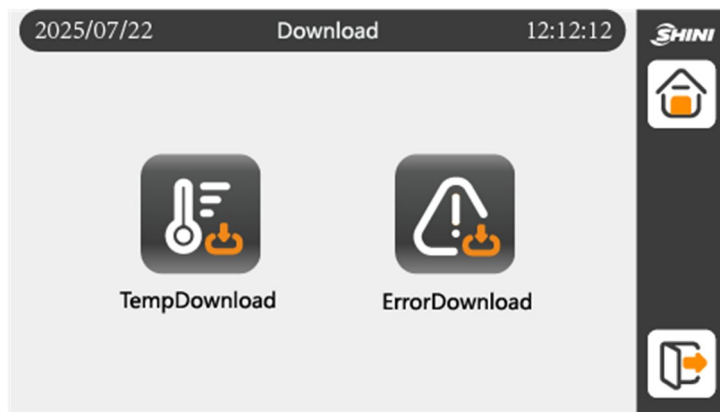

Picture 4-15: Data Download Interface

1) Temp. Data Download

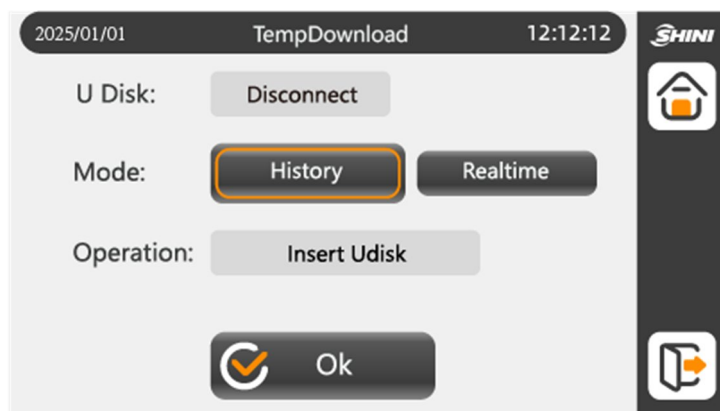

Picture 4-16: Temp. Data Download Interface

Local data backup: copy the temp. data on the display board to the U disk (the data of display board can be saved for up to 48 hrs.). Insert the U disk, wait until the "U disk" displays "connected" status, and then follow the prompts. Other operations are prohibited during the download process.

Real-time data recording: After inserting the U disk and starting the real-time data recording function, then the temp. ,pressure, flow data will be updated in real time and stored in the U disk automatically, and the recording will be interrupted after unplugging the U disk. Before unplugging the U disk, please disable the real-time data recording function first, and then unplug the U disk. Otherwise the data or U disk may be damaged.

 **Attention!**

After data export, a folder/SF51XXX will be created in the U disk root directory, and the data will be saved in Excel.

Notes! Please use U disk: FAT32 format.

2) Alarm Record Download

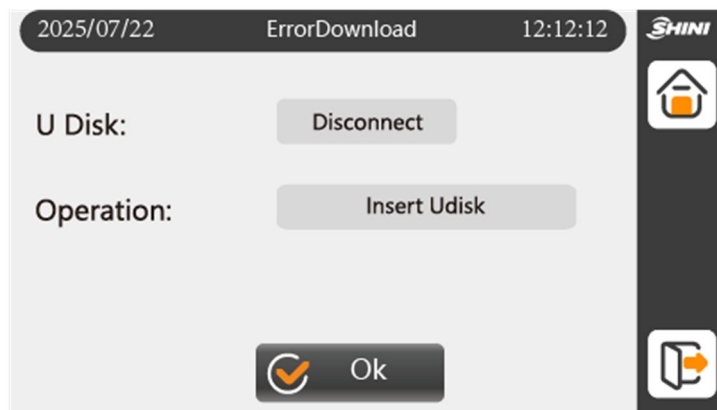

Picture 4-17: Alarm Record Download Interface

Attention!

Don't try to enter any other parameter settings, otherwise it may cause machine abnormalities if you accidentally modify any other parameters.

4.3.3 User Menu

Table 4-4: User Menu Description

Items	Parameter Name	Factory Default	Setting Range	Remarks
Common	Lock temp.	No	Yes~No	Yes: After locking, the set temp. can't be modified on the main interface. No: Set temp. can be modified on the main interface.
	Set temp.	20.0℃	5.0~30.0℃	The setting range is limited by manufacturer's parameters 【set temp. upper limit】、【set temp. lower limit】
	Start mode	local	local; local+ remote; remote	Local: The unit can only be started and stopped by local. Local + remote: The unit start and stop can be both controlled by local and

				remote. Remote: The unit can only be started and stopped by remote.
	Compressor selection	use	disable; use	
Communication	Baud rate	19200	19200; 9600; 4800	/
	Check digit	no	no; odd; even;	/
	Stop bit	1	1~2	/
	Comm. address	1	0~32	/
	Comm. address definition	Shini SLINK	Shini SLINK; GB/T 38687-2020; Haitian;	/
Ethernet	IP address 1	192	0~255	Ethernet related parameters can only be queried when the manufacturer 【Ethernet selection】 is set to "use". Note: It requires the display screen hardware to have an interface that supports Ethernet function, otherwise enabling Ethernet function will be ineffective.
	IP address 2	168	0~255	
	IP address 3	1	0~255	
	IP address 4	30	0~255	
	Subnet mask 1	255	0~255	
	Subnet mask 2	255	0~255	
	Subnet mask 3	255	0~255	
	Subnet mask 4	0	0~255	
	Gateway 1	192	0~255	
	Gateway 2	168	0~255	
	Gateway 3	1	0~255	

	Gateway 4	1	0~255	
	MAC address 1	192	0~255	
	MAC address 2	168	0~255	
	MAC address 3	1	0~255	
	MAC address 4	1	0~255	
	msg_modbus-tcp	use	disable; use	
	msg_modbus-tcp port number	502	0~30000	
System	Backlight time	0 secs.	0~255 secs.	<p>When there is no button operation beyond the set time, turn off the backlight.</p> <p>The settable range is 0 to 255 mins., and the backlight will not be turned off when it is set to 0.</p>
	Language selection	Chinese	Chinese; English	Select interface display language

5. Troubleshooting

Faults	Testing Conditions	Troubleshooting	Solutions
Compressor 1/2 high pressure	Detect after the compressor 1/2 start the 【High pressure detection delay】	Stop the compressor, and keep the pump running	Check if the sensor wiring and sensor alarm parameter settings are correct.
Compressor 1/2 low pressure	Detect after the compressor 1/2 start the 【Low pressure detection delay】		
Compressor 1/2 high low pressure	Power-on detection		
Compressor 1/2 overload	Detect when the compressor 1/2 runs	Stop the compressor, and keep the pump running	Check whether the compressor overload input is consistent with the switch value setting.
Low water temperature	Run detection	Stop the compressor, and keep the pump running	Check if the water temperature is below the set low temperature protective temperature.
High water temperature		Stop the compressor, and keep the pump running	Check if the water temperature is higher than the set high temperature protective temperature.
Open circuit of water temp. probe	Power-on detection	Stop the compressor, and keep the pump running	Check whether the temperature probe is in good contact.
Short circuit of water temp. probe			
Short circuit of anti-freeze probe			

Short circuit of anti-freeze probe			
Open circuit of ambient temp. probe			
Short circuit of ambient temp. probe			
Open circuit of liquid outlet probe			
Short circuit of liquid outlet probe			
Open circuit of return water probe			
Short circuit of return water probe			
High ambient temp.	power-on detection	stop the unit	Check if the ambient temp. is higher than the set alarm temperature value
Low ambient temp.	power-on detection	stop all the compressor, and not stop the pump	Check if the ambient temperature is lower than the set alarm temperature value
Low anti-freeze temp.	power-on detection	stop the compressor, and not stop the pump	Check if the antifreeze temp. is lower than the set alarm temperature value
High return water temp.	run detection	stop the compressor, and not stop the pump	Check whether the return water temperature is higher than the set alarm temperature value

Blower 1/2 fault	detect the compressor start	stop the compressor, and not stop the pump	Check whether the blower fault input is consistent with the switch value setting.
Insufficient chilled water flow	detect after the pump start the 【pump start delay】	stop the unit	Check whether the chilled water flow switch is consistent with the switch value setting. Check whether the flow sensor wiring and sensor alarm parameter settings are correct. When using the current conversion function, please detect the pump current.
Insufficient cooling water flow	detect after the pump start the 【pump start delay】	stop the compressor, and not stop the pump	Check whether the cooling water flow switch input is consistent with the switch quantity setting.
Pump overload	detect after pump start	stop the unit	Check whether the pump overload input is consistent with the switch value setting.
3-phase power fault	power-on detection	stop the unit	Check whether the three-phase power input is missing or in reverse; whether the switching value is correct.
Low water level	power-on detection	stop the unit	Check whether the water level input is consistent with the switching value setting.
Insufficient water pressure	detect after the pump start the 【pump start delay】	stop the unit	Check whether the water pressure sensor wiring and the sensor alarm parameter setting is correct. When using the current conversion function, please check the pump current.
Machine unit	run detection	Once the unit is shut down, it can't be turned on (The unit	

needs maintenance		accumulated operating time exceeds the set value 【unit maintenance time】	
High pressure 1/2 sensor fault	power-on detection	stop the unit	Detect the sensor wiring
Low pressure 1/2 sensor fault			
Flow sensor fault			
Water pressure sensor fault			

6. Repair and Maintenance

Check whether the displayer and buttons work normally.
Cycle: Daily

Check whether the pressure value is kept around the target value.
Cycle: Daily

Check whether the bypass solenoid valve can open normally and whether there is abnormal sound and vibration.
Cycle: Daily;

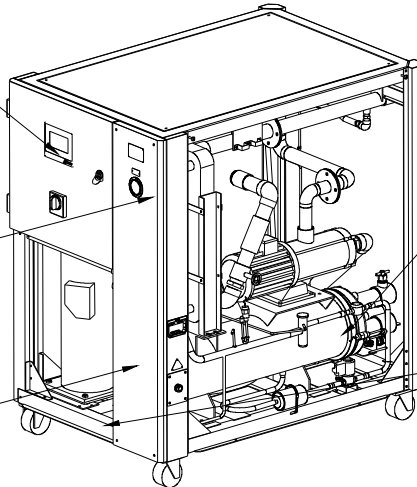

Check whether there are bubbles in the sight glass, and whether the moisture indicator color exceeds the standard. If it exceeds the standard, replace the dry filter.
Cycle: Monthly

Check whether there is abnormal noise and vibration during the compressor operation. To avoid hand hurt as the compressor bottom, the bottom temperature can't exceed 50 ℃.
Cycle: Daily

Check whether the water system has leakage or is abnormal;
Discharge cycle: monthly;

Check whether there is abnormal noise and vibration during pump operation. The pump surface temperature shall not exceed 70 ℃.
Cycle: Daily;

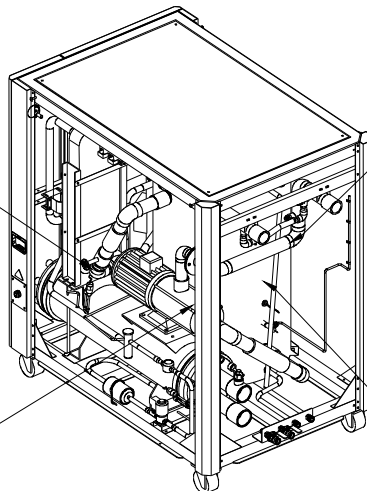

Check whether it is blocked or fully opened (the water pressure is abnormal, and the system water flow is abnormal). If it is blocked, remove the valve body and clean the diaphragm.
Discharge cycle: Weekly;

Check the water tank inside has been polluted or scaled, and whether the water quality is turbid and polluted;
Cycle: monthly;



Attention!

All repair work should be done by qualified personnel only to avoid damage to the machine or personnel injury.

In order to operate the machine rightly and safely, please caution the matter follows:

- 1) Don't turn off the main power switch to stop the machine, except emergency situation.

- 2) When machine shuts down and gives alarms, press the main power switch of the machine first (the alarm light goes out), and then check the cause of the fault. Don't start the machine forcibly before troubleshooting.
- 3) Please check periodically to prolong the machine's service life and prevent the safety accident.
- 4) The water used in the system must have water treatment, because the high alkaline water will accelerate the corrosion of the copper pipe, and reduce the service life of the heat exchanger. The PH value of water is in the range of 7.0-8.5.
- 5) Keep the machine room dry, clean and well ventilated.
- 6) The operation and service of the machine should be done by qualified technician only

Please take notice that the disassembly and the inspection of the machines are hazardous when the machines are running!

6.1 Components Maintenance

6.1.1 Condenser

The SIC-W-R2 series adopts tube-in-shell condenser. In the use process, it will inevitably adhere to dust and sundries, which reduces the heat exchange rate. The condenser should be cleaned regularly so that the machine can run stably.

If the cooling water has been under water treatment, it is advised that firstly use hydrogen peroxide to kill bacteria and then use a high pressure water rifle to flush it, at last check whether there is still scale. If the cooling water is not processed under water treatment, clean it with citric acid and sulfamic acid along with inhibitor, and then flush it with a high pressure water rifle. Passivation is need after acid washing, and the passivator can be purchased for relevant treatment.



Attention!

Do the cleaning work every half-year in the environment with little dust, but you must do the work every month in the environment with a great deal of dusts, and under the severe environment you had better see the situation to do the work.

6.1.2 Evaporator

The inner flank of the heat emission pipe will pile up a great deal of water scale after a long time use of the evaporator, which will influence the heat emission effect, so it is necessary to clean the evaporator at fixed periods in order to keep its working performance. If the circulation has been under water treatment, it is advised that firstly use hydrogen peroxide to kill bacteria and then use a high pressure water rifle to flush it, at last check whether there is still scale. If the circulation is not processed under water treatment, clean it with citric acid and sulfamic acid along with inhibitor, and then flush it with a high pressure water rifle. Passivation is need after acid washing, and the passivator can be purchased for relevant treatment.

The cleaning of the evaporator:

- 1) Connect the inlet and outlet of the machine's chilled water with a hose.
- 2) Mix the bactericide and water in a certain proportion (The specific proportion should be mixed according to the requirements) into a solution, pour it into the machine water tank, and start to clean the pump of the machine.
- 3) After cleaning and removing the bactericide solution, it's necessary to add running water into the water tank for several times and clean repeatedly to ensure that there is no residual bactericide solution in the system.

6.1.3 Disk Filter

After using the built-in disk filter in the water system for a period of time, it must be cleaned, and the displayer will have clear indication. At this time, please remove the machine's side plate, and open the manual valve at the drain outlet of the disk filter to discharge for 5 minutes. After treatment, close the manual valve at the filter drain outlet, and restore the side plate to run the water chiller continuously.



Attention!

In the environment of temperature below 0°C, when shut down or store the machine, drain the water in the water tank through the outlet. If the evaporator freezes, it needs to melt the ice before startup.

6.2 Maintenance Schedule

6.2.1 About the Machine

Model _____ SN _____ Production Date _____
Voltage ___ Φ _____ V Frequency _____ Hz Total power _____ kW

6.2.2 Check after Installation

- Check the pipes are all correctly connected.
- Check if there are leakages in the piping system.
- Check if there are breaks in the welding joint.

Electrical Installation

- Voltage: _____ V _____ Hz
- Fuse specification: 1phase _____ A 3 phase _____ A
- Check phase sequence of power supply.

6.2.3 Daily Checking

- Check switch functions.
- Check all the electrical wires.
- Check whether pressure gauges are accurate.
- Check whether compressor temperature is normal.
- Check whether cooling water circulation is normal.

6.2.4 Weekly Checking

- Check electrical connections.
- Check protection & alarm function of the water chiller.
- Check whether set point of high-low pressure switch is normal.

6.2.5 Monthly Checking

- Check whether the circulation pipeline has leakage.
- Check whether there are bubbles in liquid indicator.
- Check whether there is abnormal sound in pump.
- Check whether there is scale formation in tank.

6.2.6 Tri-monthly Checking

Check whether condenser is under blockage.

6.2.7 Half-yearly Checking

Check and clean the filter and expansion valve.

Check system performance.

Clean condenser.

6.2.8 Yearly Checking

Check whether the contactor is normal.

6.2.9 3-year Checking

PC board renewal.

No fuse breaker renewal.

Appendix:

SHINI Comm. Address Table (1)

Water Chiller SIC Comm. Variable Table					Comm. Protocol: MODBUS-RTU
D-Map (30000+i)	English	Chinese	Range	Definition	Type
0	Unit Status	unit running status	0-4	0: idle 1: ready to start 2: run 3: delayed shutdown 4: fault	Read -only
1	I/O/Input/Output1	switch input status 1	0-65535	※ 2 (operating with bit address) as shown in SHINI Bit Address Variable Definition Table (II)	Read -only
2	I/O/Input/Output2	switch input status 2	/		Read -only
3	Relay status	relay status	0-65535	※ 2 (operating with bit address) as shown in SHINI Bit Address Variable Definition Table (II)	Read -only
4	Alarm Message1	fault info. 1	0-65535	※ 2 (operating with bit address) (as shown in SHINI Bit Address Variable Definition Table (II))	Read -only
5	Alarm Message2	fault info. 2	0-65535	※ 2 (operating with bit address) as shown in	Read -only

				SHINI Bit Address Variable Definition Table (II)	
6	Alarm Message3	fault info. 3	0-65535	※ 2 (operating with bit address) as shown in SHINI Bit Address Variable Definition Table (II)	Read -only
7	Water Temperature	water temp.		unit 0.1°C	Read -only
8	Water Temperature	water temp.		unit 0.1°F	Read -only
9	Ambient Temperature	ambient temp.		unit 0.1°C	Read -only
10	Ambient Temperature	ambient temp.		unit 0.1°F	Read -only
11	Antifreeze Temperature	anti-freezing temp.		unit 0.1°C	Read -only
12	Antifreeze Temperature	anti-freezing temp.		unit 0.1°F	Read -only
13	Return Water Temperature	return water temp.		unit 0.1°C	Read -only
14	Return Water Temperature	return water temp.		unit 0.1°F	Read -only
15	Liquid Refrigant Temperature	liquid outlet temp.		unit 0.1°C	Read -only
16	Reserve	standby	/		Read -only
17	Reserve	standby	/		Read -only
18	Reserve	standby	/		Read -only
19	Reserve	standby	/		Read -only
20	Reserve	standby	/		Read -only
21	Reserve	standby	/		Read -only
22	Process Water	chilled water		0.1 L/min	Read -only

	Flow	flow			
23	Reserve	standby	/		Read -only
24	Water Pressure	water pressure		unit 0.1bar	Read -only
25	High Pressure1	high pressure 1		unit 0.1bar	Read -only
26	Low Pressure1	low pressure 1		unit 0.1bar	Read -only
27	High Pressure2	high pressure 2		unit 0.1bar	Read -only
28	Low Pressure2	low pressure 2		unit 0.1bar	Read -only
256	X	X		Version information (version number represented by ACSII characters)	Read -only
257	1	1			Read -only
.....			Read -only
288	Reserve	standby			Read -only
512	User operation command	User operation command	112-118	0x72: pump on/off 0x70: compressor on/off 0x76: silence 0x75: reset 0x73: power on 0x74: power off	Write-only
1024	Lock Temperature	Lock temp.	0~1	0: The set temperature can be quickly modified on the main interface 1: Lock the set temperature	Write/read
1025	Set Temperature	Set temp. (Unit Celsius)	min...max	min=[set the temp. lower limit] max=[set the temp. upper limit]	Write/read
1026	Set Temperature	Set temp. (Unit Fahrenheit)	min...max	min=[set the temp. lower limit] max=[set the temp. upper limit]	Write/read
1027	On/Off Mode	On/off method	0~2	0: Local: The unit can	Write/read

				<p>only be started and stopped by local.</p> <p>1: Local + remote: The unit start and stop can be both controlled by local and remote.</p> <p>2: Remote: The unit can only be started and stopped by remote.</p>	
1028	Backlight Time	backlight time	0~255	<p>When set to 0, the backlight remains constantly on; When set to non-zero, if the controller is not operated within the set time, the controller's backlight will be turned off.</p>	Write/read
1029	Multi-language	multi-lingual	0~1	<p>0: Chinese</p> <p>1: English</p>	Write/read
1030	Compressor ON	compressor start selection	0~1	<p>0: Disable</p> <p>1: Use</p>	Write/read
1031	Temp Units	temperature unit	0~1	<p>0: Celsius</p> <p>1: Fahrenheit</p>	Write/read
512	Pump ON/OFF	pump on/off command	0, 65280	<p>0XFF00: pump on/off</p> <p>0X0000: command invalid</p>	Write-only
513	Compressor ON/OFF	compressor on/off command	0, 65280	<p>0XFF00: compressor on/off</p> <p>0X0000: command invalid</p>	Write-only
514	Silence	silence command	0, 65280	<p>0XFF00: silence</p> <p>0X0000: command invalid</p>	Write-only
515	Reset	reset command	0, 65280	0XFF00: reset	Write-only

				0X0000: command invalid	
516	ON	power-on command	0, 65280	0XFF00: power on 0X0000: command invalid	Write-only
517	OFF	power-off command	0, 65280	0XFF00: power off 0X0000: command invalid	Write-only
...			Write-only
	543	Reserve			Write-only

SHINI Comm. Address Table (2)

Water Chiller SIC Comm. Variable Table					Comm. Protocol : MODBUS-R TU
D-Map (30000+i)	Name	BIT			
		0	1	2	3
		4	5	6	7
		8	9	10	11
		12	13	14	15
1	Switch input status 1	remote switch	standby	standby	compressor 1 overload
		pump overload	blower 1 fault	water level switch	chilled water flow switch
		standby	3-phase power switch	standby	standby
		compressor 2 overload	blower 2 fault	cooling water flow switch	standby
3	relay status	standby	compressor 2	hot gas by-pass valve 1	hot gas by-pass valve 2
		standby	compressor 1	pump	alarm
		standby	blower 2 high	standby	blower 2 low

			speed		speed
		drainage solenoid valve	blower 1 high speed	blower 1 low speed	standby
4	Fault info. 1	compressor 1 high pressure	compressor 1 low pressure	compressor 1 overload	water low level
		insufficient chilled water flow	pump overload	blower 1 fault	standby
		three-phase power fault	low water temperature	high water temperature	open circuit of water temp. probe
		water temp. probe short circuit	parameter error	machine needs maintenance	high ambient temperature
5	Fault info. 2	open circuit of ambient temperature probe	short circuit of ambient temperature probe	open circuit of anti-freeze probe	short circuit of anti-freeze probe
		low anti-freeze temp.	compressor 2 high pressure	compressor 2 low pressure	compressor 2 overload
		blower 2 fault	high pressure 2 sensor fault	low pressure 2 sensor fault	high compressor 2 low pressure
		standby	standby	standby	standby
6	Fault info. 3	standby	low ambient temperature	open circuit of liquid outlet probe	short circuit of liquid outlet probe
		standby	standby	Insufficient cooling water flow	Insufficient water pressure
		open circuit of return water probe	short circuit of return water probe	high return water temp.	high pressure 1 sensor fault
		low pressure 1 sensor fault	flow sensor fault	water pressure	compressor 1 high low

				sensor fault	pressure
--	--	--	--	--------------	----------

Haitian Comm. Address Table (1)

Water Chiller SIC Comm. Variable Table					Comm. Protocol: MODBUS-RTU
D-Map (30000+i)	English	Chinese	Range	Definition	Type
30000	Unit Status	unit running status	0-4	0: idle 1: ready to start 2: run 3: delay shutdown 4: fault	Read -only
30003	Relay status	relay status	0-65535	※ 2 Operate with bit address, as shown in Haitian Bit Address Variables Definition Table (2)	Read -only
30007	Water Temperature	water temperature		unit 0.1°C	Read -only
30008	Water Temperature	water temperature		unit 0.1°F	Read -only
41308	Max. Temperature Set Value	temp. upper limit		unit 0.1°C	Read -only
41309	Max. Temperature Set Value	temp. upper limit		unit 0.1°F	Read -only
41310	Min. Temperature Set Value	temp. lower limit		unit 0.1°C	Read -only

41311	Min. Temperature Set Value	temp. lower limit		unit 0.1°F	Read -only
256	X	X		Version information (version number represented by ASCII characters)	Write-only
257	1	1			Write-only
.....			Write-only
288	Reserve	standby			Write-only
512	User operation command	user operation command	115-118	0x76: silence 0x75: reset 0x73: power on 0x74: power on	Write-only
41025	Set Temperature	set temp. (unit: Celsius)	min...max	min=[set temp. lower limit] max=[set temp. upper limit]	Write/read
41026	Set Temperature	set temp. (unit:Fahrenhei t)	min...max	min=[set temp. lower limit] max=[set temp. upper limit]	Write/read
514	Silence	silence command	0, 65280	0XFF00: mute, 0X0000: invalid command	Write-only
515	Reset	reset command	0, 65280	0XFF00: reset, 0X0000: invalid command	Write-only
516	ON	power-on command	0, 65280	0XFF00: power on, 0X0000: invalid command	Write-only
517	OFF	power-off command	0, 65280	0XFF00: power off, 0X0000: invalid command	Write-only
...			Write-only
542	Reserve	/	/	/	Write-only

Haitian Bit Address Variable Table (2)

Water Chiller SIC Comm. Variable Table	Comm. Protocol: MODBUS-RT U
---	--

D-Map (30000+i)	Name	BIT			
		0	1	2	3
		4	5	6	7
		8	9	10	11
		12	13	14	15
30003	relay status	compressor 2	compressor 1	blower high speed	standby
		blower low speed	pump	bypass valve	alarm
		standby	standby	standby	standby
		standby	standby	standby	standby

National Standard GB/T 38687-2020 Comm. Address (1)

Water Chiller SIC Comm. Variable Table					Comm. protocol: MODBUS-RTU
D-Map (30000+i)	English	Chinese	Range	Explanation	Type
0	Unit Status	Machine unit operating status	0-65535	※ 2 (operated by bit address) as shown in GB/T 38687-2020 Bit Address Variable Definition Table (II)	Read-only
1	I/O/Input/Output1	switch input status 1	0-65535	※ 2 (operated by bit address) as shown in GB/T 38687-2020 Bit Address Variable Definition Table (II)	Read-only
2	I/O/Input/Output	switch input	/		Read-only

	put2	status 2			
3	Relay status	relay status	0-65535	※ 2 (operated by bit address) as shown in GB/T 38687-2020 Bit Address Variable Definition Table (II)	Read-only
4	Alarm Message1	fault info. 1	0-65535	※ 2 (operated by bit address) as shown in GB/T 38687-2020 Bit Address Variable Definition Table (II)	Read-only
5	Alarm Message2	fault info. 2	0-65535	※ 2 (operated by bit address) as shown in GB/T 38687-2020 Bit Address Variable Definition Table (II)	Read-only
6	Alarm Message3	fault info. 3	0-65535	※ 2 (operated by bit address) as shown in GB/T 38687-2020 Bit Address Variable Definition Table (II)	Read-only
7	Alarm Message4	fault info. 4	0-65535	※ 2 (operated by bit address) as shown in GB/T 38687-2020 Bit Address Variable Definition Table (II)	
9	Water Temperature	water temp.		unit: 0.1°C /0.1°F	Read-only
10	Antifreeze Temperature	anti-freeze temp.		unit: 0.1°C /0.1°F	Read-only
11	Ambient Temperature	ambient temp.		unit: 0.1°F /0.1°F	Read-only
12	Process Water Flow	chilled water flow		0.1 L/min	Read-only

13	Water Pressure	water pressure		0.1 bar	Read-only
14	Run Time	unit accumulative run time		hour	Read-only
256	X	X		Version information (version number represented by ACSII characters)	Read-only
257	1	1			Read-only
.....			Read-only
288	Reserve	standby			Read-only
512	User operation command	user operation command	112-118	0x72: pump on/off 0x70: compressor on/off 0x76: silence 0x75: reset 0x73: power on 0x74: power off	Write-only
0	Set Temperature	set temp.	min...max	min=[set temp. lower limit] max=[set temp. upper limit]	Write/read
1	Max. Temperature Set Value	set temp. lower limit	min...max	min=[set temp. lower limit] max=80°C/176°F	Write/read
2	Min. Temperature Set Value	set temp. lower limit	min...max	min=-38.0°C/-36.4°F max=[set temp. upper limit]	Write/read
3	/	/	/	/	Write/read
4	/	/	/	/	Write/read
5	Temp Units	temp. unit	0~1	0: Celsius 1: Fahrenheit	Write/read
512	Pump ON/OFF	pump on/off command	0, 65280	0XFF00: pump on/off, 0X0000: invalid command	Write-only
513	Compressor ON/OFF	compressor on/off command	0, 65280	0XFF00: compressor on/off 0X0000: invalid command	Write-only
514	Silence	silence command	0, 65280	0XFF00: silence ,0X0000: invalid command	Write-only

515	Reset	reset command	0, 65280	0XFF00: set, 0X0000: invalid command	Write-only
516	ON	power on command	0, 65280	0XFF00: power on, 0X0000: invalid command	Write-only
517	OFF	power on command	0, 65280	0XFF00: power off, 0X0000: invalid command	Write-only
...			Write-only
542	Reserve	standby			Write-only

National Standard GB/T 38687-2020 Comm. Address (2)

Water Chiller SIC Comm. Variable Table					Comm. Protocol: MODBUS-RTU
D-Map (30000+i)	Name	BIT			
		0	1	2	3
		4	5	6	7
		8	9	10	11
		12	13	14	15
1	Switch input status 1	remote switch	standby	standby	compressor 1 overload
		pump overload	blower 1 fault	water level	chilled water flow switch
		standby	three-phase power switch	standby	standby
		compressor 2 overload	blower 2 fault	cooling water flow switch	standby
3	Relay status	pump	blower 1	compressor 1	hot-gas bypass valve 1
		alarm	blower 2	compressor 2	hot-gas bypass valve 2

		standby	standby	standby	standby
		standby	standby	standby	standby
4	Fault info.1	compressor 1 high pressure	compressor 1 low pressure	compressor 1 overload	low water level
		Insufficient chilled water flow	pump overload	blower 1 fault	standby
		3-phase power fault	low water temp.	high water temp.	open circuit of water temp. probe
		short circuit of water temperature probe	parameter abnormality	machine needs maintenance	high ambient temperature
5	Fault info.2	open circuit of ambient temp. probe	short circuit of ambient temp. probe	open circuit of anti-freeze probe	anti-freezing probe short circuit
		low anti-freezing temperature	compressor 2 high pressure	compressor 2 low pressure	compressor 2 overload
		blower 2 overload	standby	standby	standby
		standby	standby	standby	standby
6	Fault info.3	standby	low ambient temperature	open circuit of liquid outlet probe	short circuit of liquid outlet probe
		standby	standby	insufficient cooling water flow	insufficient water pressure
		open circuit of return water probe	short circuit of return water probe	High return water temp.	high pressure 1 sensor fault
		low pressure 1 sensor fault	flow sensor fault	water pressure sensor fault	compressor 1 high low pressure

7	Fault info. 4	high pressure 2 sensor fault	low pressure 2 sensor fault	compressor 2 high low pressure	standby
		standby	standby	standby	standby
		standby	standby	standby	standby
		standby	standby	standby	standby